

INSTALLATION MANUAL

Comm-Box for NMC AIR+



© COPYRIGHT 2011, NETAFIM

NO PARTS OF THIS PUBLICATION MAY BE REPRODUCED, STORED IN AN AUTOMATED DATA FILE OR MADE PUBLIC IN ANY FORM OR BY ANY MEANS, WHETHER ELECTRONIC, MECHANICAL, BY PHOTOCOPYING, RECORDING OR IN ANY OTHER MANNER WITHOUT PRIOR WRITTEN PERMISSION OF THE PUBLISHER.

ALTHOUGH NETAFIM TAKES THE GREATEST POSSIBLE CARE IN DESIGNING AND PRODUCING BOTH ITS PRODUCTS AND THE ASSOCIATED DOCUMENTATION, THEY MAY STILL INCLUDE FAULTS.

NETAFIM WILL NOT ACCEPT RESPONSIBILITY FOR DAMAGE RESULTING FROM THE USE OF NETAFIM'S PRODUCTS OR THE USE OF THIS MANUAL.

NETAFIM RESERVES THE RIGHT TO MAKE CHANGES AND IMPROVEMENTS TO ITS PRODUCTS AND/OR THE ASSOCIATED DOCUMENTATION WITHOUT PRIOR NOTICE

VERSION 3.5.6 REV 1.4 110786

Table of Contents

1	Introduction to Comm-Box	4
1.1	Supported Devices	4
1.2	Part Numbers	4
1.3	What Comes in the Package	4
2	Hardware Installation	5
2.1	Comm-Box Ports	5
2.2	Mounting the Comm-Box	6
2.3	Grounding	6
2.4	Connecting the Comm-Box to the Internet	7
2.5	Connecting the Comm-Box to Peripheral Devices	7
2.6	Connecting the Comm-Box to a Controller	7
2.6.1	Controller to Junction Box Wiring	8
2.6.2	RLINK One to Junction Box Wiring	8
2.6.3	Comm-Box to Junction Box Wiring	9
2.6.4	Wiring Topology	12
2.6.5	Termination	12
3	Technical Data	14
3.1	Comm-Box	14
3.2	Junction Box	15
4	Group Management	16
4.1	What is a Group	16
4.2	Activating the Farm	17
4.3	Invite Users	22
4.4	Local Log In	25
5	RotemNet Web and NMC AIR+	26
5.1	User Settings	27
5.2	RotemNet Web Functionality	28
5.2.1	Farm Settings Tab	28
5.2.2	House Scan Tab	31
5.2.3	Diagnostics Tab	32
5.2.4	About Tab	33
5.3	Software Upgrade	33
6	WARRANTY	36

1 INTRODUCTION TO COMM-BOX

NOTE This manual details how to set up and run the Comm-Box. The controllers' software program is documented in separate manuals.

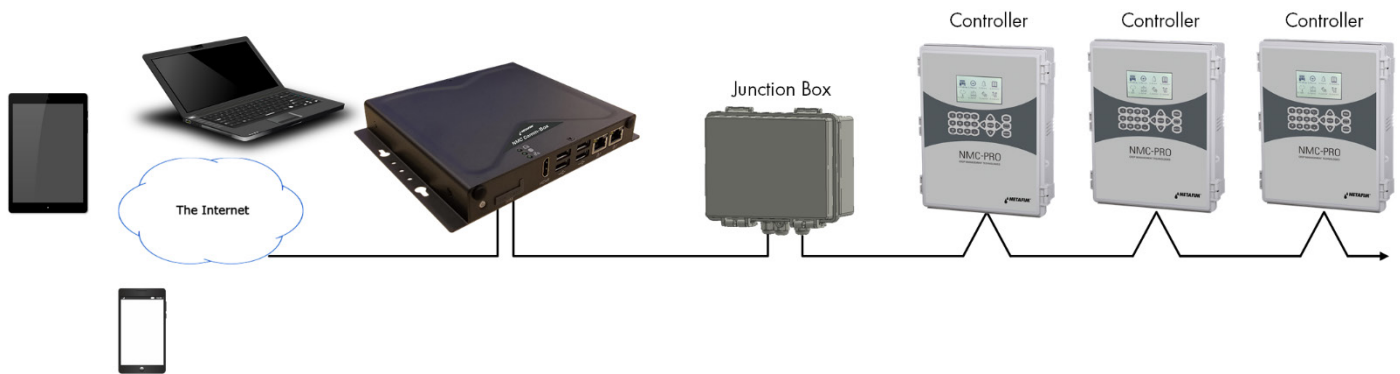

Comm-Box provides complete access to your Netafim irrigation controllers, including monitoring and control capabilities (NMC AIR+), from any device, anywhere. From one computer, tablet, or smartphone, you can manage an entire network.

- Cloud-based access to controllers
 - Multiple, simultaneous users have network access
- Multiple communication pathways
 - Built-in internet and telephone connectivity
 - Cellular connectivity
- Local communication via wired or wireless communication
- Status reports provide critical information on irrigation functions and statistics
- Push notifications

1.1 Supported Devices

The following product versions support the NMC AIR+ application:

- NMC PRO Version 3.08.05 and above.
- NMC JUNIOR Version 9.08.05 and above

NOTE Before upgrading the NMC PRO from Version 3.06.XX or 3.07.XX to 3.08.XX the first time, copy (photograph) the settings of the controllers' tables. These tables can't be uploaded from a data plug; they must be entered manually.

1.2 Part Numbers

Netafim PN	Munters PN	Description	Comments
74340-000004	P-NMC-CMBOX*	COMMBOX-EN-NMC-JB485-WEB	(Without modem)
74340-000005	P-NMC-CMBOX-M*	COMMBOX-EN-NMC-CMGB-JB485-WEB	(With Global modem)

1.3 What Comes in the Package

- Comm-Box
- Junction Box
- Power Supply Cables 115VAC and 230VAC

2 HARDWARE INSTALLATION

This document details how to install Netafim's Comm-Box unit. Installation consists of:

- Comm-Box Ports
- Mounting the Comm-Box
- Grounding
- Connecting the Comm-Box to the Internet
- Connecting the Comm-Box to Peripheral Devices
- Connecting the Comm-Box to a Controller

NOTE No software installation is required.

2.1 Comm-Box Ports

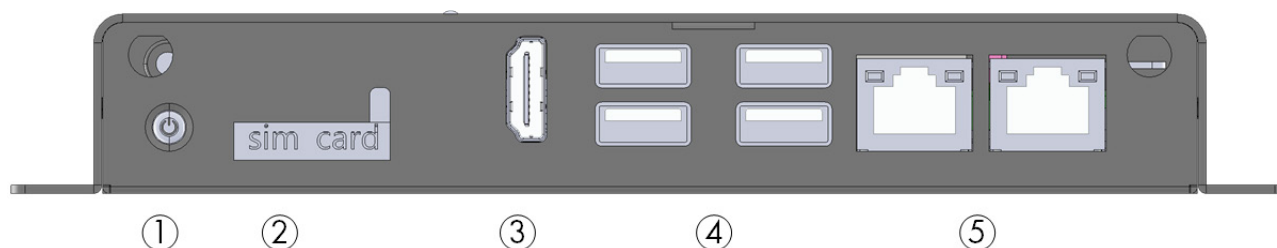

Figure 1: Front View

Number	Description
1	On/off button
2	SIM Card port (4G card can be used with a modem for cellular connectivity)
3	HDMI port (refer to Connecting the Comm-Box to Peripheral Devices)
4	USB ports (refer to Connecting the Comm-Box to Peripheral Devices)
5	Internet ports (refer to Connecting the Comm-Box to the Internet)

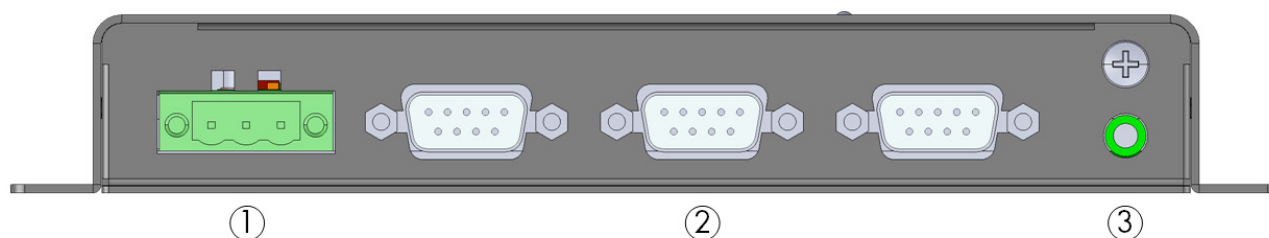

Figure 2: Rear View

HARDWARE INSTALLATION

Number	Description
1 & 2	External box cable connectors
3	Audio out

2.2 Mounting the Comm-Box

- Using the screws provided, mount the unit.

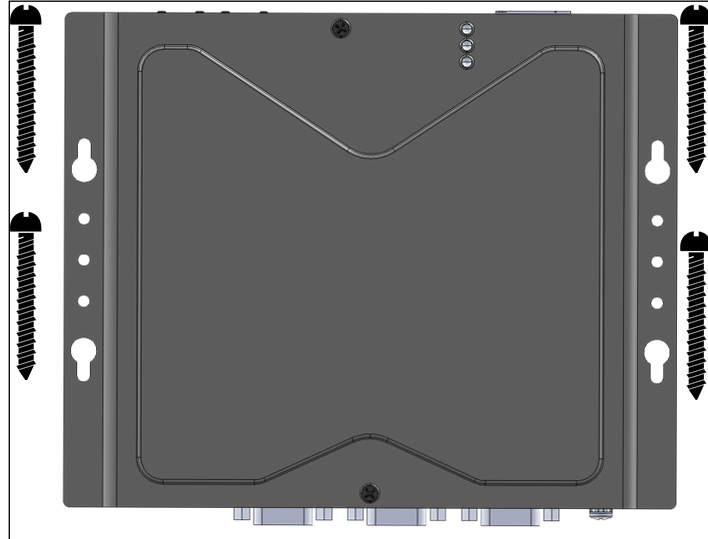

Figure 3: Unit and Mounting Screws

2.3 Grounding

- Connect the ground cable to the dedicated ground terminal.

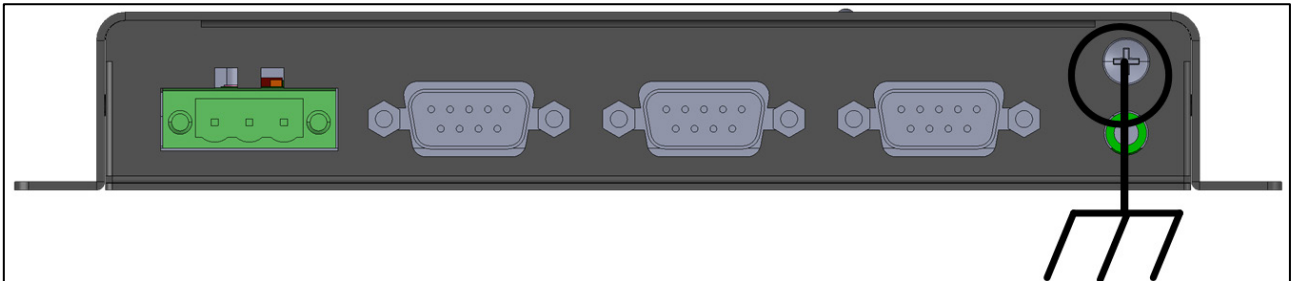

Figure 4: Grounding Schematic

CAUTION Ground the Comm-Box always!

HARDWARE INSTALLATION

2.4 Connecting the Comm-Box to the Internet

- Connect the Comm-Box to your Internet connection/modem.

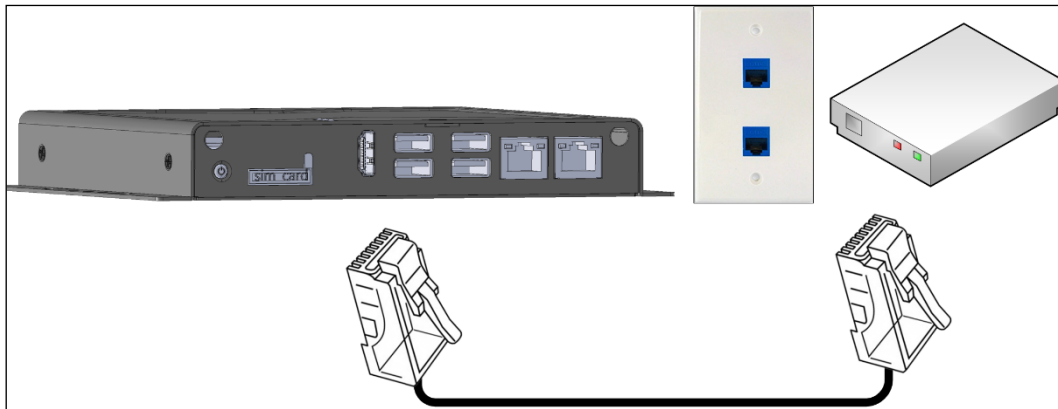

Figure 5: Internet Connection

2.5 Connecting the Comm-Box to Peripheral Devices

When required, connect a screen, keyboard, or mouse to the Comm-Box (via the USB/HDMI ports).

NOTE Connect the screen to the Comm-Box using an HDMI cable only. Do not use any other type of cable and an HDMI adapter.



Figure 6: Peripheral Devices

2.6 Connecting the Comm-Box to a Controller

The only step in installing a Comm-Box that requires wiring is if the Comm-Box is connected directly to a controller (instead of to a communication unit). In this situation the Comm-Box must be wired to the controller communication card via a Junction Box.

- Controller to Junction Box Wiring
- RLINK One to Junction Box Wiring
- Comm-Box to Junction Box Wiring
- Wiring Topology
- Termination

HARDWARE INSTALLATION

WARNING! Disconnect the power before beginning!

WARNING! Only an authorized electrical technician may perform this procedure!

2.6.1 Controller to Junction Box Wiring

In the controller, connect the Comm-Box to the controller's communication card, via the Junction Box. Refer to the following illustrations.

NOTE NMC irrigation installation support RS-485 wiring only.

1. The cable between the controller and the Junction Box should be a 3-wire twisted shielded cable (22 or 24 AWG).
2. Connect the wiring as follows:
 - COM to COM
 - The Comm-Box A port is connected to Controller's A port.
 - The Comm-Box B port is connected to Controller's B port.
3. The final controller in any chain or branch requires a 120-ohm terminator.
4. Connect the cable shield wire to the controller ground strip.

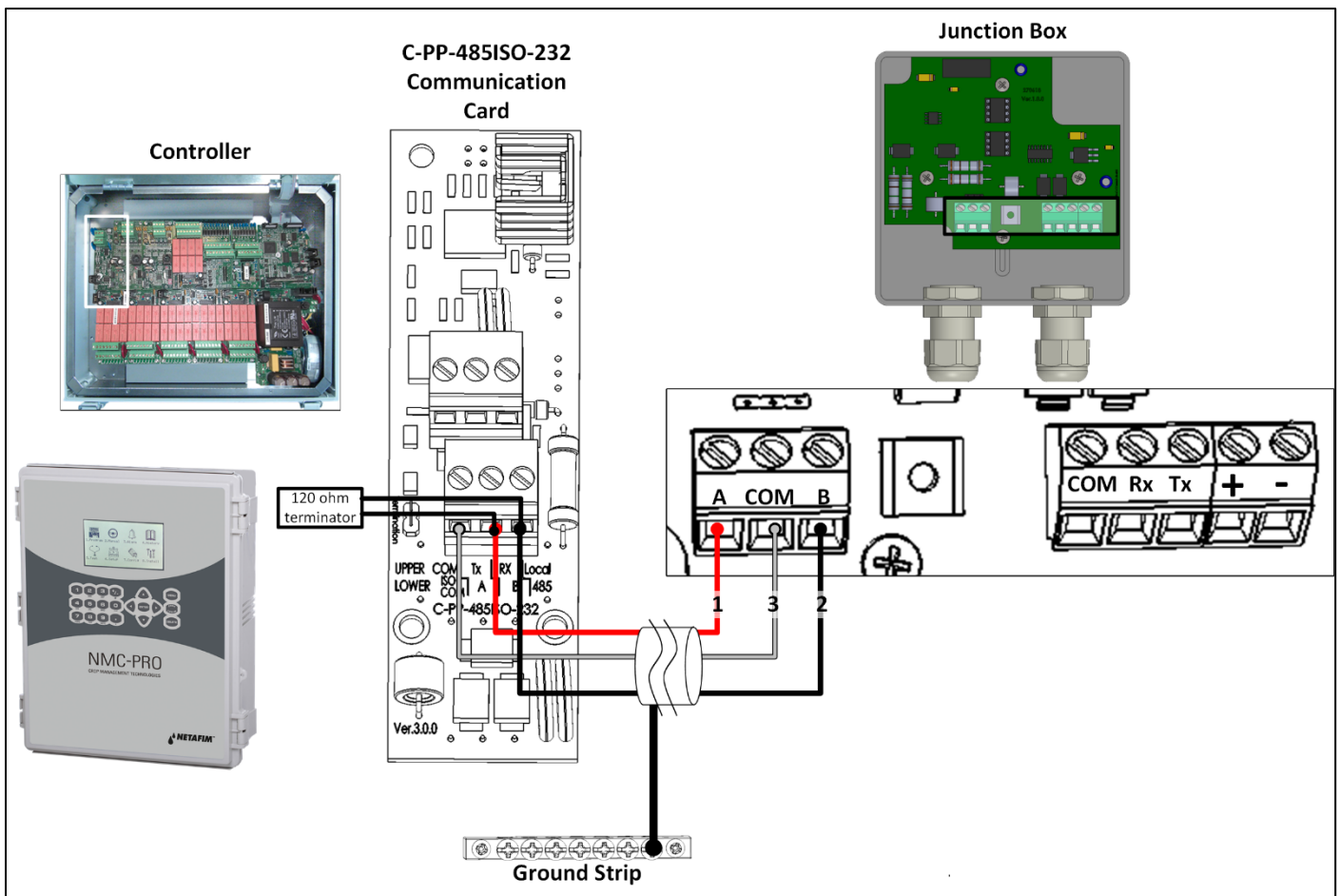

Figure 7: NMC PRO RS-485 Wiring

2.6.2 RLINK One to Junction Box Wiring

1. The cable between the external connection box and the RLINK One should be a 3-wire twisted shielded cable (22 or 24 AWG).
2. Connect the wiring as follows:
 - COM to COM

HARDWARE INSTALLATION

- The Comm-Box A port is connected to Controller's A port.
 - The Comm-Box B port is connected to Controller's B port.
3. The final controller in any chain or branch requires a 120-ohm terminator. Refer to Termination, page 12.
 4. Connect the cable shield wire to the controller ground strip.

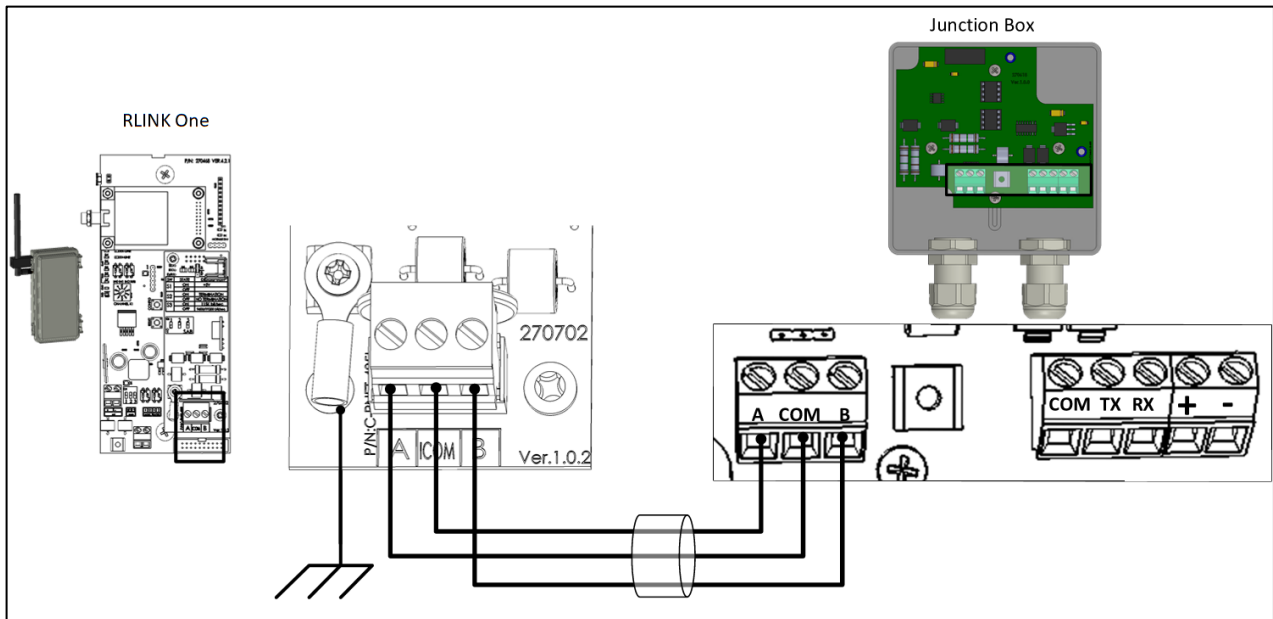

Figure 8: RLINK One RS-485 Wiring

2.6.3 Comm-Box to Junction Box Wiring

- The Comm-Box comes with the power supply wired to the unit. See Figure 9.

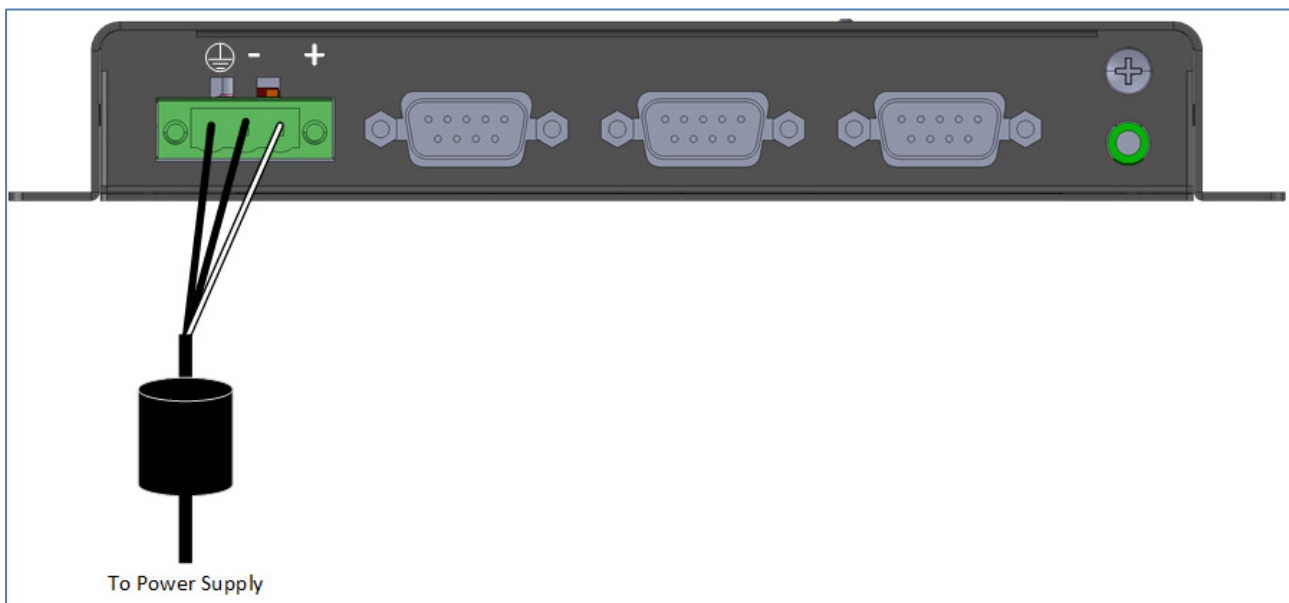

Figure 9: Comm-Box Power Supply Wiring

- 1 Insert the Junction Box 9-Pin Connector into COM1 (see Figure 10).

HARDWARE INSTALLATION

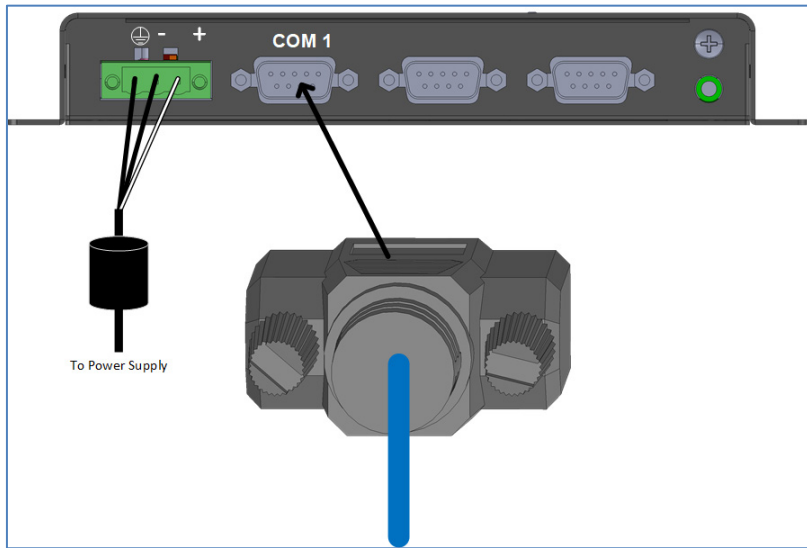

Figure 10: Insert 9 Pin Connector

2. Insert the two wires coming from the Junction Box cable into the ports (see Figure 11 and Figure 12).

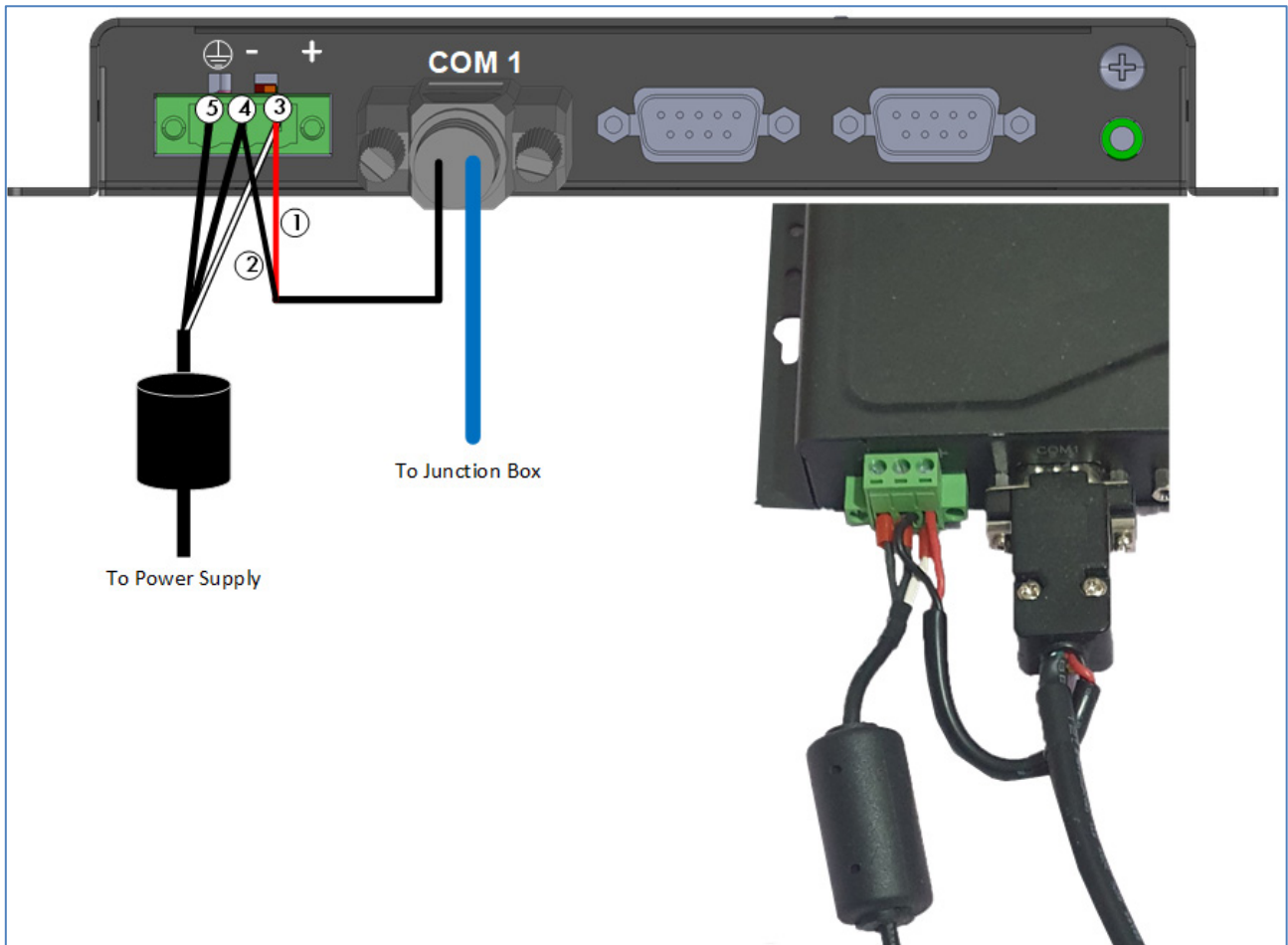

Figure 11: Junction Box Wiring to Comm-Box

HARDWARE INSTALLATION

Table 1: Wiring Details

Cable source	Color	Function	Number
Junction Box Cable	Red	+VCC (24 DC)	1
	Black	-VCC (Junction Box)	2
Power Supply Cable*	White	+VCC (Junction Box) (24 DC)	3
	Black	-VCC	4
	Black	Ground	5

*These wires come preconnected to the Comm-Box. If they need to be reattached, place the white cable (#3) in the port as shown in Figure 4. Place both black cables into the ports as shown in Figure 4; either cable can be placed in either port.

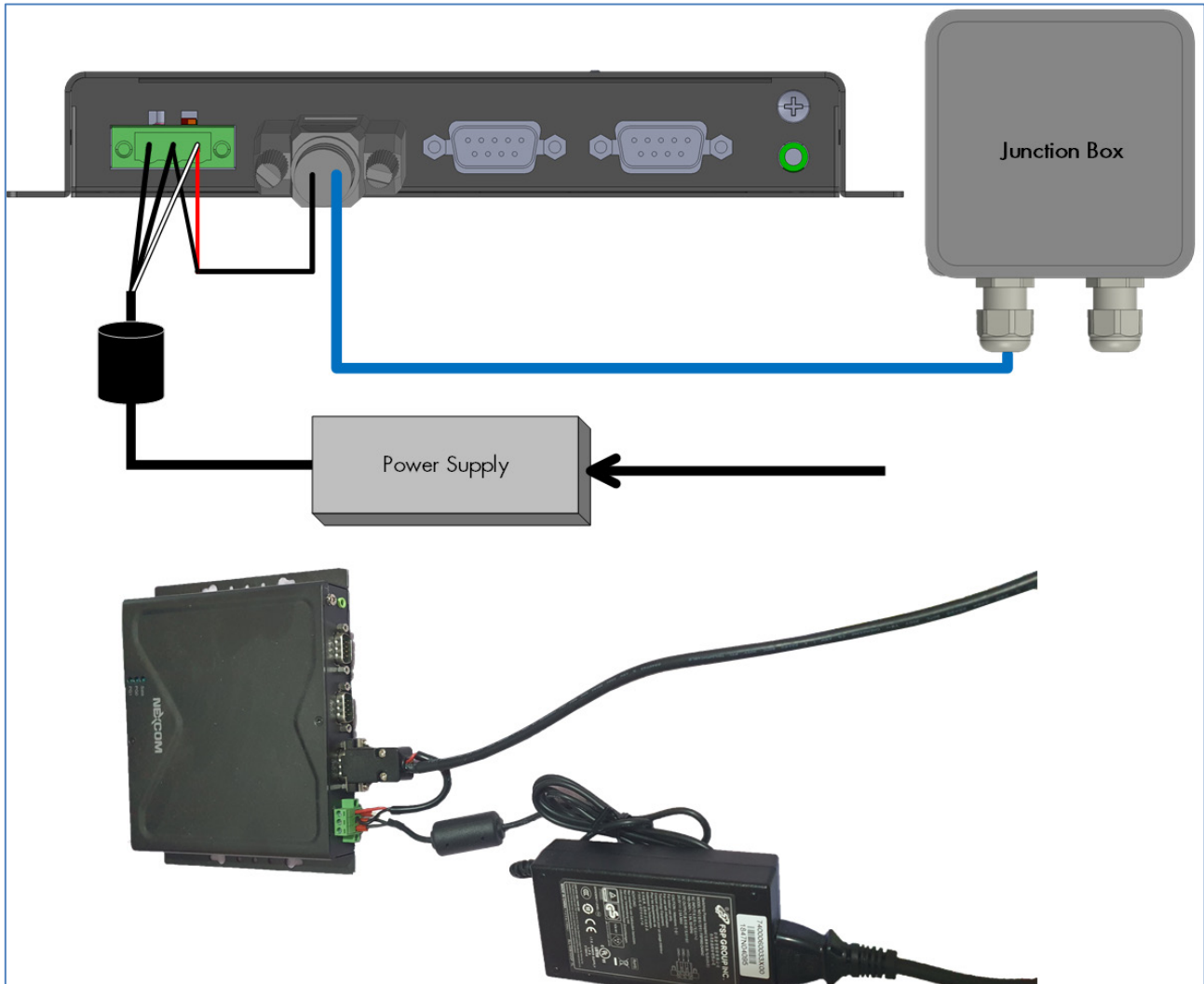

Figure 12: Power Supply – Comm-Box – Junction Box Setup

HARDWARE INSTALLATION

2.6.4 Wiring Topology

When connecting the Comm-Box to controllers via an **RS-485 infrastructure**, use one of the following allowed topologies to ensure signal integrity.

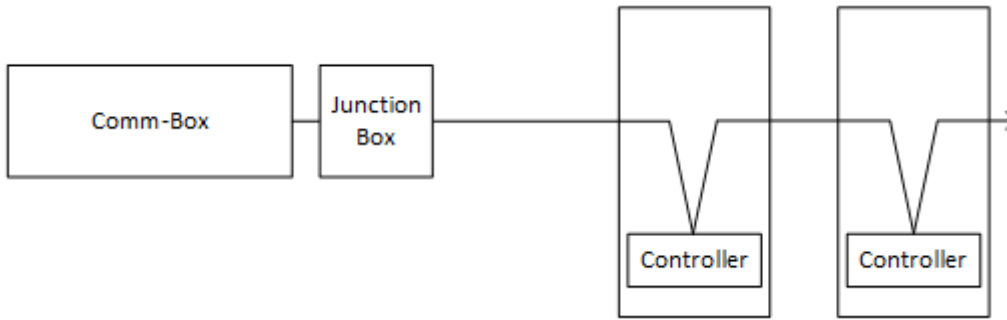

Figure 13: Direct connections

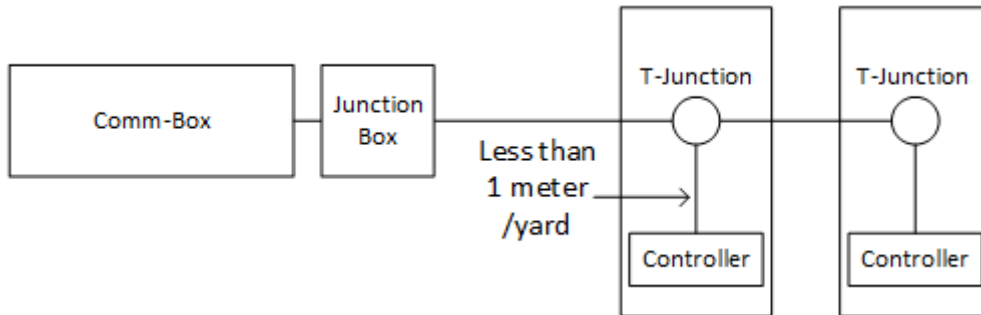

Figure 14: T-Junction (permitted)

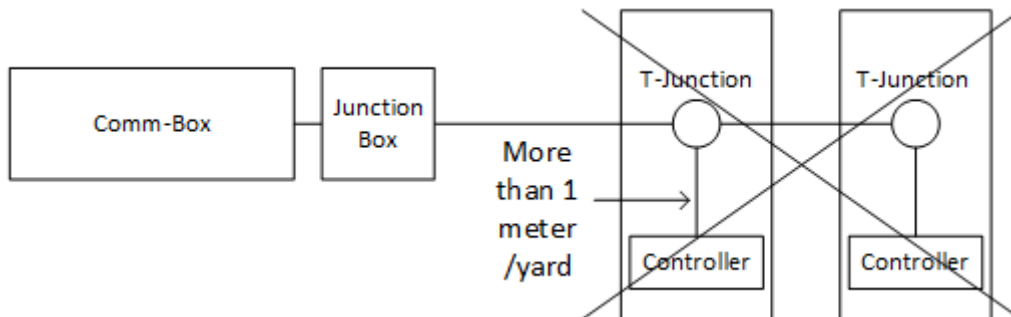

Figure 15: T-Junction (not permitted)

2.6.5 Termination

Termination, installing 120-ohm termination resistors at the beginning and end units of each chain of Comm-Box and controllers, ensures reliable communication in RS-485 infrastructures. The following illustrations show where to install the resistors. Depending on the topology, install the resistors in the T-box, the terminal controller, or the Netafim Repeater.

- Termination Topologies
- Termination Wiring

HARDWARE INSTALLATION

2.6.5.1 Termination Topologies

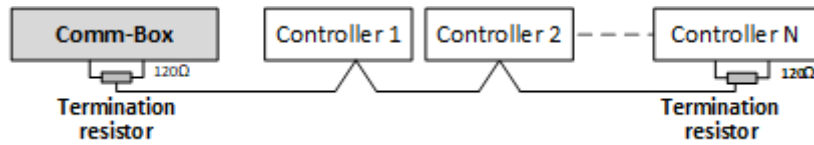

Figure 16: Topology 1: Comm-Box/Controller Termination

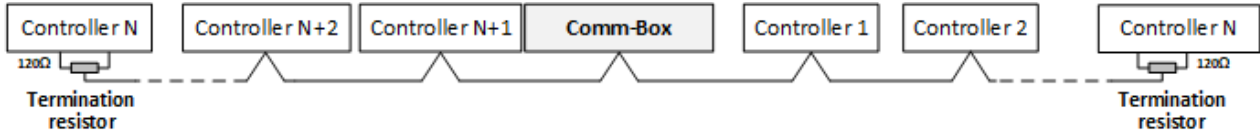

Figure 17: Topology 2: Controller Termination

2.6.5.2 Termination Wiring

- Comm-Box: Install the termination resistor in the Junction Box.

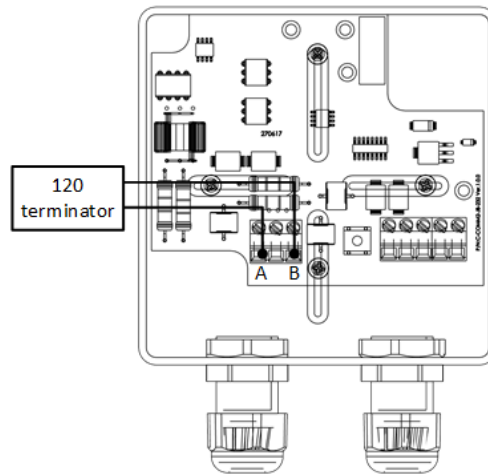





Figure 18: Junction Termination

3 TECHNICAL DATA

- Comm-Box
- Junction Box

3.1 Comm-Box

Power Supply	
Power Input	<ul style="list-style-type: none"> • 24V DC +/-20% • 1 x 24V, 60W power adapter
CAUTION Unit should be powered by Limited Energy Source per IEC 61010-1 or Limited Power Source per IEC 60950-1 or IEC 62368-1	
Temperature Range	
Operating Temperature Range	0° to +50° C / 32° to 125° F
Storage Temperature Range	-10° to +70° C / 14° to 158° F
Environmental Specifications	
<ul style="list-style-type: none"> • Indoor use only • Altitude: -400 m to 2000 m • Relative Humidity: 0 – 95% • Main supply voltage fluctuation up to 5% • Overvoltage category: OVCII • Pollution degree: PD2 • Ingress Protection: IPX0 	
Housing	
Metal Box Dimensions (W x H x D)	162 x 26 x 150 mm (without wall-mount bracket)
Certification	
  	

3.2 Junction Box

Power Supply	
Junction Box Power Input	24 VDC, 30 mA
CAUTION Unit should be powered by Limited Energy Source per IEC 61010-1 or Limited Power Source per IEC 60950-1 or IEC 62368-1	
Temperature Range	
Operating Temperature Range	0° to +45° C / 32° to 113° F
Storage Temperature Range	-10° to +70° C / 14° to 158° F
Environmental Specifications	
<ul style="list-style-type: none"> • Indoor use only • Altitude: -400 m to 2000 m • Relative Humidity: 0 – 90% • Main supply voltage fluctuation up to 5% • Overvoltage category: OVCII • Pollution degree: PD2 • Ingress Protection: IP50 	

4 GROUP MANAGEMENT

When using the Comm-Box to connect to your farm(s), you must:

- [create \(activate\) a farm](#)
- [invites users](#)

4.1 What is a Group

A group is the virtual device used to manage your farms. Using the RotemNet Web application, the group manager defines each user's permissions (which farms he can see and what functions he can carry out).



Figure 19: Group Example

As an example, an account manager has sent up two Groups and wants to add three different users to his account (Figure 20).

1. User 1 is assigned access rights to Farm 1.
2. User 2 is assigned access rights to Farm 2.
3. User 3 is assigned access rights to Farm 1 and Farm 2.
4. In addition, User 1 is also assigned access rights to Farm 3, which is in an entirely different group.

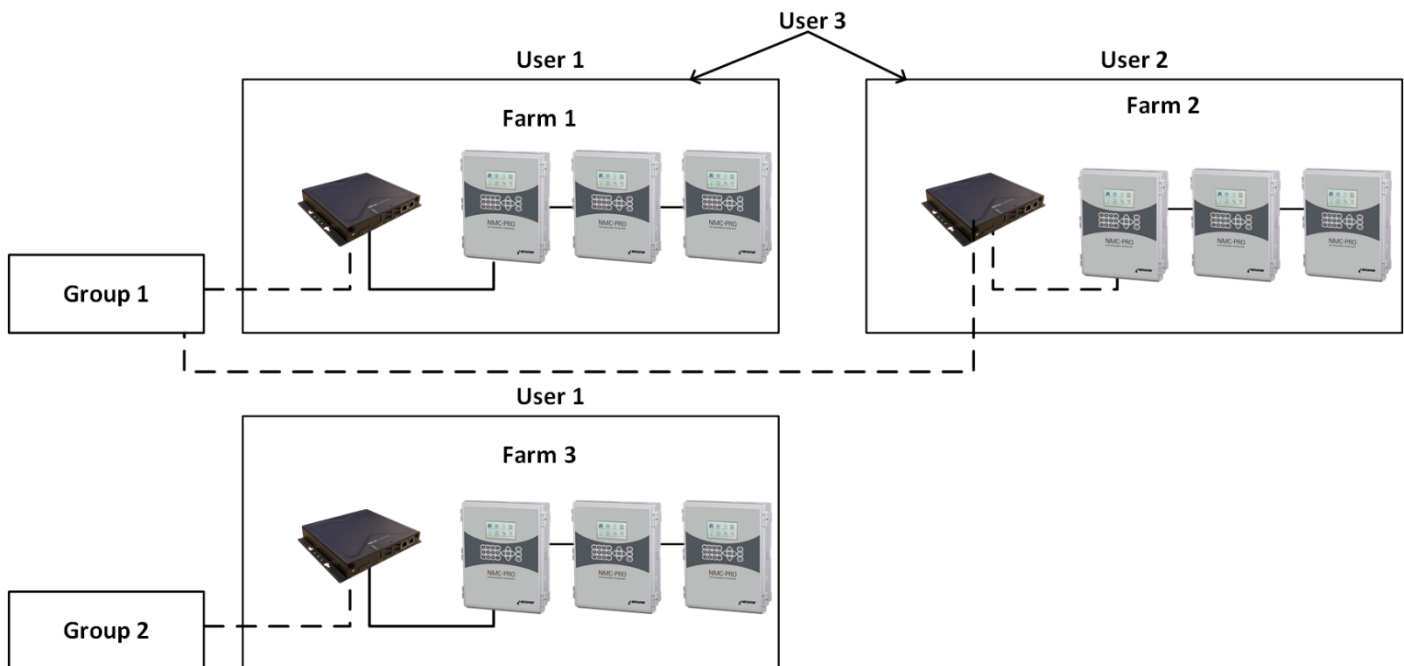

Figure 20: User Assignment

Any combination is possible.

4.2 Activating the Farm

The first time that you power up a Comm-Box, you need to activate a farm.

1. Connect the Comm-Box to a screen, keyboard, and mouse. Apply power. The Farm Activation screen appears.

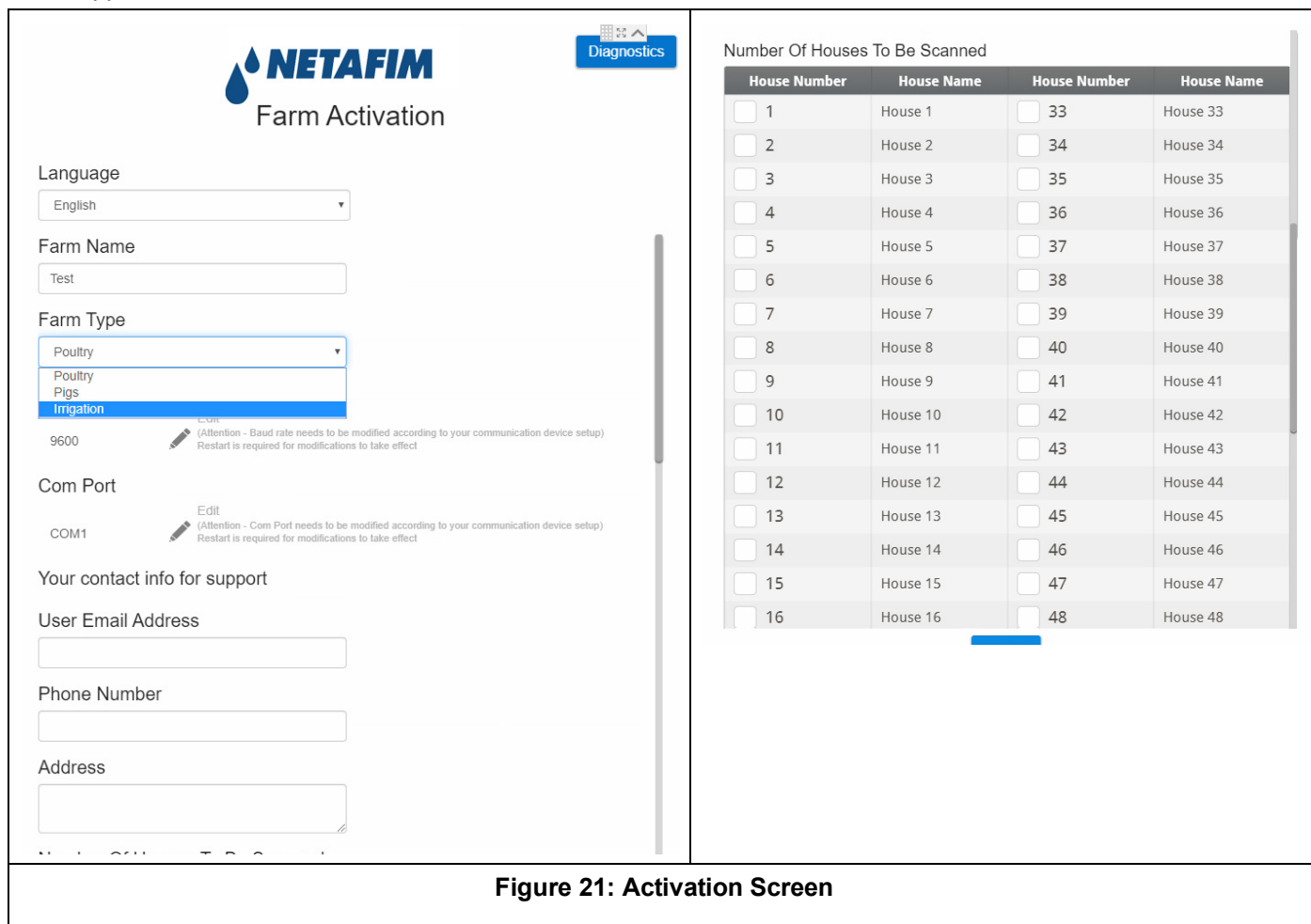

Figure 21: Activation Screen

2. Fill in the fields:

- Name: Type in the farm name.
- Farm Type: Choose the type from the drop-down list.
- Baud rate/Com Port: Comm-Box has a default setting of 9600 BPS, respectively. If you need to change these setting, click on the pencil and choose a setting from the drop-down list.
 - Verify that the Comm-Box and controller baud rates are the same.
 - The Com Port must be Com Port 1.
- Contact info: This is optional information which enables Netafim to contact you if needed.

NOTE You can edit all these settings in RotemNet Web.

- Mark the checkboxes of the houses to be scanned. Mark at least one house. As an option, the house names can be edited.

3. Click **Activate**. A pop up appears asking if you want to scan your farmhouses.

GROUP MANAGEMENT

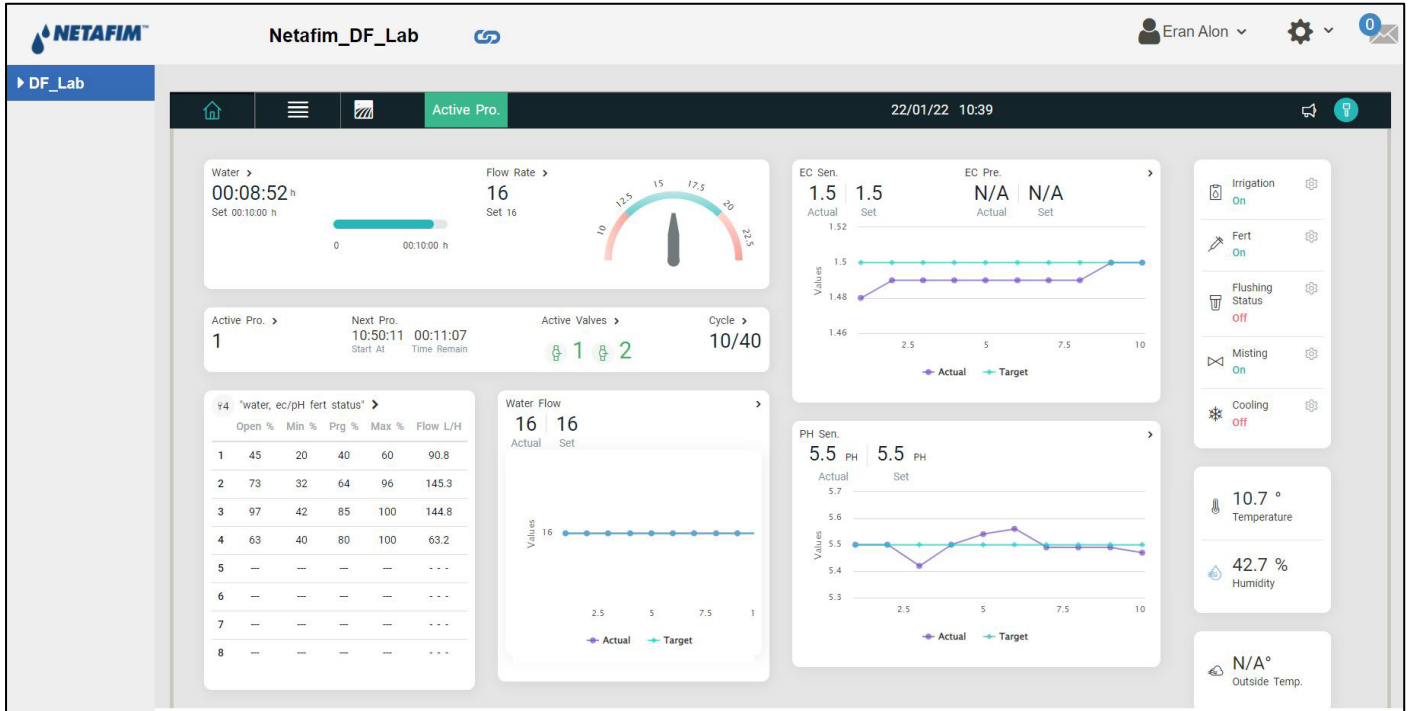
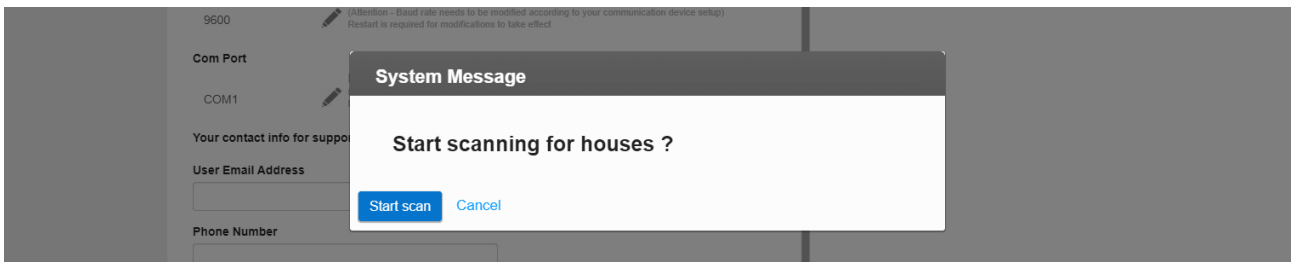



Figure 22: NMC AIR+ Dashboard

4. Click the settings icon () and go to farm settings. The following screen appears.

NETAFIM

Test

House 1

Farm settings External Devices Push Notifications Local Users Data Collect Activity log

The farm is not connected to the web [Connect](#) [Software Update](#)

Farm Name
Test

Farm Type
Irrigation

Baud Rate
9600 [Edit](#)
(Attention - Baud rate needs to be modified according to your communication device setup)
Restart is required for modifications to take effect

Com Port
COM1 [Edit](#)
(Attention - Com Port needs to be modified according to your communication device setup)
Restart is required for modifications to take effect

Your contact info for support

User Email Address

Phone Number

Address

Date And Time
Thursday, December 23, 2021 12:48 AM [Change Date And Time](#)

Time zone
(UTC-08:00) Pacific Time (US & Canada)

Number Of Houses To Be Scanned [Edit](#)

Figure 23: Initial Farm Settings Screen

5. Click **Connect**. The following screen appears.

The image shows the initial sign-in form for RotemNet Web. At the top is the NETAFIM logo and the text "RotemNet Web". Below this are two dropdown menus: "Selected Region" with "AMERICA" selected, and "Language" with "English" selected. There are two text input fields: "User Email Address" containing the placeholder "My RotemNetWeb User Email address" and an empty "Password" field. At the bottom left is a blue "Login" button, and at the bottom right is a blue "DEMO" button. Below the buttons are two links: "Not registered yet ? [Sign Up Now](#)" and "[Forgot Password](#)".

Figure 24: Initial Sign In Form

6. From the drop-down lists, select the region and language.

CAUTION If you are using the Irrigation application, select America only.

7. Click **Sign Up Now**. The following screen appears.

The image shows the "Create a New User Screen" within the "Farm Web Connection" window. The window has a dark header with the title "Farm Web Connection". Below the header are two tabs: "1 User Login" (which is active and highlighted in blue) and "2 Attach A Farm To A Group". Under the "User Login" tab, there is a section titled "Create a new user" with four text input fields: "User Name" (placeholder: "My New RotemNetWeb User Name"), "User Email Address", "Password", and "Confirm Password". At the bottom left of this section are two buttons: a grey "Cancel" button and a blue "Create a user" button. At the bottom right of the window is a blue "Close" link.

Figure 25: Create a New User Screen

8. Fill in all fields and click **Create a User**.

Farm Web Connection

1 **User Login** 2 Attach A Farm To A Group

Create a new user

User Name
Customer 1

User Email Address
testcommbox201@gmail.com

Password
.....

Confirm Password
.....

Cancel Create a user

Close

Figure 26: Create a User (Example)

9. Click **Attach a Farm to A Group**. The following screen appears:

Farm Web Connection

1 User Login 2 **Attach A Farm To A Group**

Attach This Farm To A Farms Group

What Is Farm's Group ?
A virtual unit that combines farms together and enables to manage multiple farms easily.
Note:Each farm must be attached to a farm group even if the group consist **one farm only**.
A farm can be attached to more then one group.

Please select one or more groups from your list of groups below to be attached to your new farm or a new group.

<input type="checkbox"/>	Group Name	Owner
<input checked="" type="checkbox"/>	New Farm Group Name	Customer 1

Add a Group

Close Attach To Group

Figure 27: Group Screen (1)

10. Write the name of the farm group that you want to create and click **Attach to Group**.

Farm Web Connection

1 User Login 2 **Attach A Farm To A Group**

Attach This Farm To A Farms Group

What is Farm's Group ?
A virtual unit that combines farms together and enables to manage multiple farms easily.
Note: Each farm must be attached to a farm group even if the group consist **one farm only**.
A farm can be attached to more then one group.

Please select one or more groups from your list of groups below to be attached to your new farm or a new group.

<input checked="" type="checkbox"/>	Group Name	Owner
<input checked="" type="checkbox"/>	Group 1	Customer 1

Figure 28: Farm Attached to Group

NOTE To create new groups, click Add a Group.

4.3 Invite Users

The following section details how to invite news users and define the user privileges.

4.3.1 Sending an Invitation

1. The person to be invited must be registered in the system.
 - o If the user has signed up to rotemnetweb.com, proceed to Step 2.
 - a. If the invitee is not registered in the system, go to <https://rotemnetweb.com/>.

NETAFIM™

Selected Region
AMERICA

Language
English

User Email Address
My RotemNetWeb User Email address

Password

Not registered yet ? [Sign Up Now](#)
[Forgot Password](#)

- b. Click **Sign Up Now**.

GROUP MANAGEMENT

- c. Fill out the fields and click **Sign Up**.
- d. Proceed to Step 2.
2. Disconnect the computer screen from the Comm-Box.
3. Sign in (using the email address and password that you used during activation) to the Comm-Box via the web at <https://www.rotanetweb.com/>.

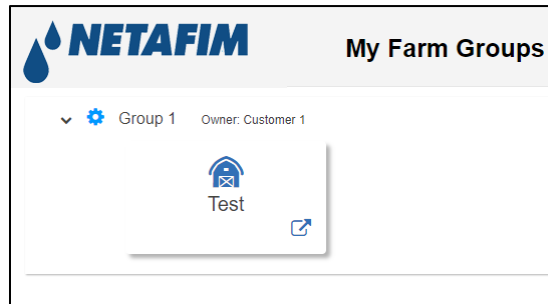



Figure 29: My Farm Groups

4. Click the gear icon . The following screen appears listing the active users.

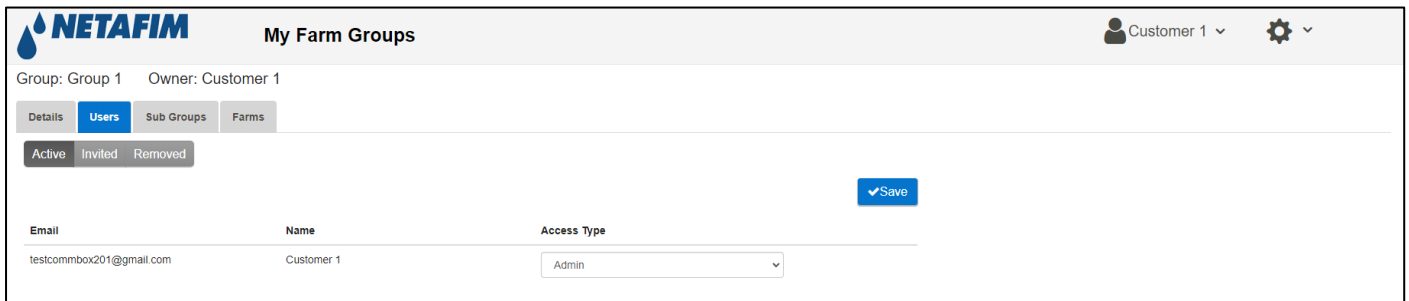

Figure 30: Active Users Screen

5. Click **Invited**.

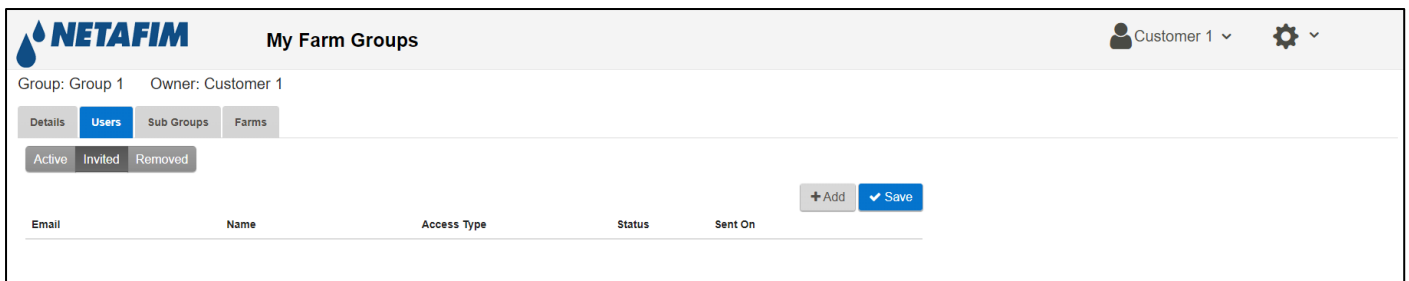

Figure 31: Add a New User Screen

6. Click **Add**.
 - a. Fill out the fields.
 - b. Define the user privilege (See below for details).
 - c. Click Invite. The invitee receives the following email:

Dear Customer ,

User name: ben.

You are welcome to connect to account name: Group 1.

Please [accept this account](#) in the RotemNetWeb application .

Once you accept the connection you will be able to view/manage the account.

Yours,
RotemNetWeb team

Figure 32: Email Invitation (Example)

4.3.2 User Privileges

Defining the privileges defines what functions the user can perform in both the CommBox and in the NMC Air+.

• CommBox User Rights:

- ◆ Admin: User can edit all unit parameters including functions related to farm settings and farm ownership.
- ◆ Read/Write: User can edit all unit parameters but cannot perform any functions related to farm settings. (Farm Settings does not appear for users having Read/Write access).
- ◆ Read Only: User can only view the CommBox units' parameters; no changes can be made.
- ◆ Unauthorized: TBD. (Currently used as read only)
- ◆ Support: TBD. (Currently used as read only)

• Web App User Rights:

- ◆ Farm Owner/Admin: User can edit all unit parameters including functions related to farm settings (including attaching a farm to a group) and inviting new users.
- ◆ Read/Write: User can edit all unit parameters but cannot perform any functions related to farm settings (not visible).
- ◆ Read Only: User can only view the units' parameters; no changes can be made.
- ◆ Unauthorized: TBD. (Currently used as read only)
- ◆ Support: TBD. (Currently used as read only)

4.4 Local Log In

In the event that:

- You restart your system
- Comm-Box logs off (this can happen automatically if you are not using system)
- Power goes off

you need to log on to the Comm-Box **locally**. The username and password of this login are different from the ones used when logging on to the Web.

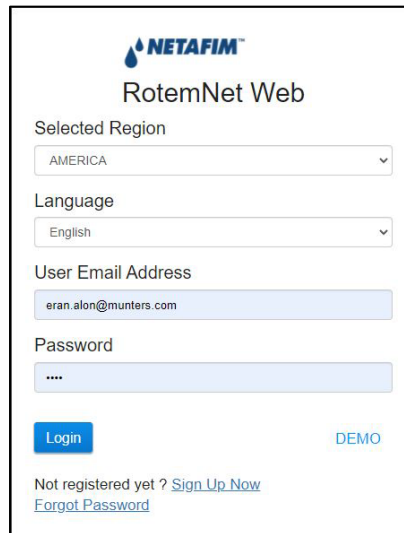

Figure 33: Local Log In

- Enter the username and password. The defaults are:
 - Username: "Farm Owner"
 - Password: "admin"

NOTE The username cannot be changed. You can change the password after logging in.

NOTE After logging in locally, you will need to log in to the Web.

5 ROTEMNET WEB AND NMC AIR+

The following sections describe how to use the RotemNet Web functions. Controller functions are described in the product manuals.

- User Settings
- RotemNet Web Functionality
- Software Upgrade

After signing in, an initial screen appears. The screen that appears depends on the controllers connected to the Comm-Box.

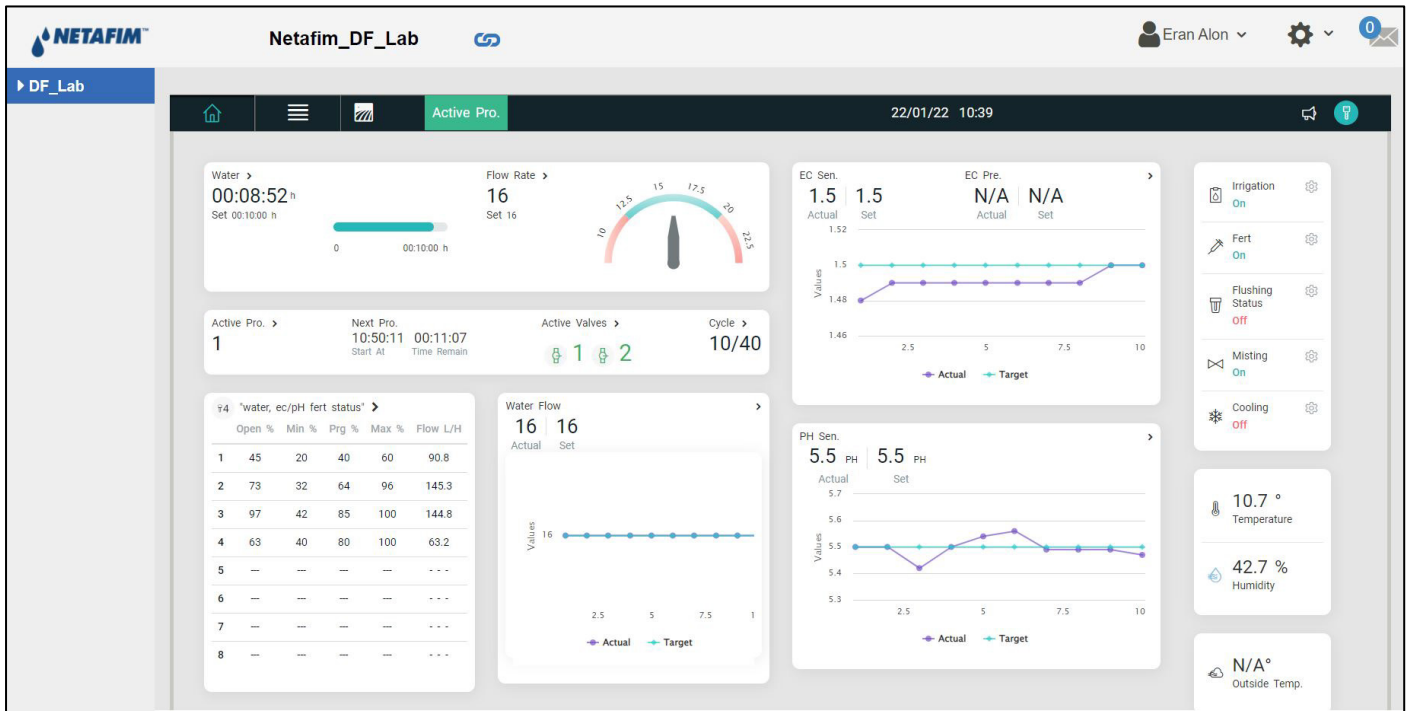





Figure 34: NMC AIR+ Dashboard



- Click on **House** to go to that controller functionality.
- Click on  to configure RotemNet Web functionality.
- Click on  to configure the user definitions.

5.1 User Settings

 User Settings

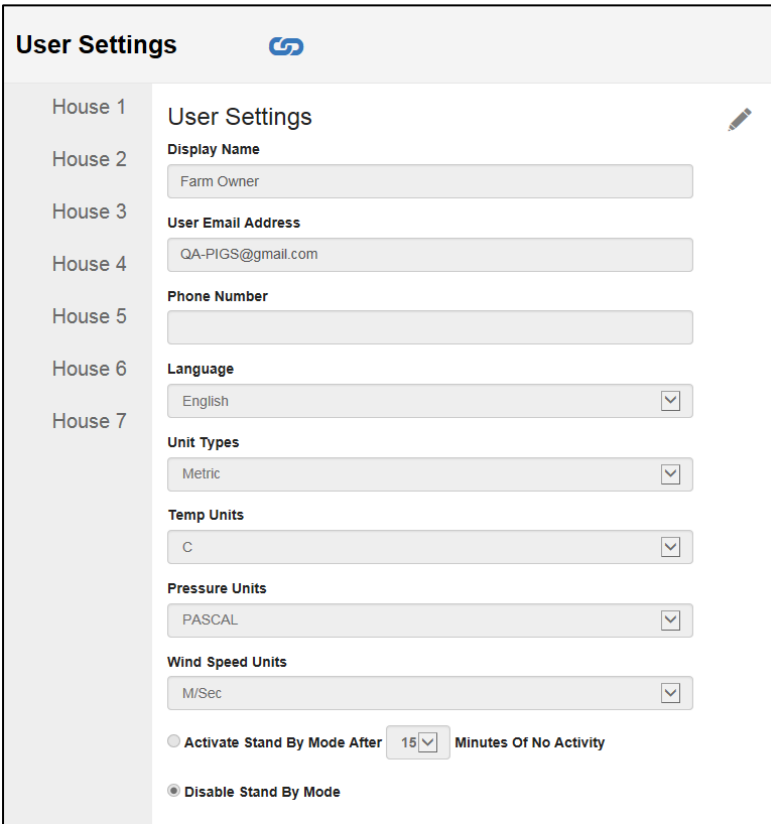
This screen defines how information appears on the screen. In Farm Owner, select the following screen appears.



- To edit, click . Fill in the following fields as required.
 - Display name: Name that appears on the User Setting screen.
 - User email address
 - Phone number
 - Language: Chose from the drop-down list
 - Unit types: Metric or English
 - Temp Units: Celsius or Fahrenheit
 - Pressure Units
 - Wind Speed Units
 - Disable or enable standby by mode (if the latter, define the amount of time that needs to pass before the mode is activated).
- Click  to save any changes.

5.2 RotemNet Web Functionality

The following section describes the RotemNet Web functions.

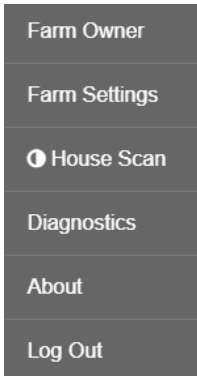

- Farm Settings Tab
- House Scan Tab
- Diagnostics Tab
- About Tab

NOTE Only the farm owner can view the Farm Owner, Farm Settings, and House Scan tabs.

5.2.1 Farm Settings Tab

- Farm Settings
- External Devices
- Push Notifications
- Local Users
- Data Collect
- Activity Log

NOTE The “Push Notifications” and “Local Users” tabs appear only on a computer screen connected directly to the Comm-Box.

5.2.1.1 Farm Settings

Use this screen to define functions related to Comm-Box's connection to your farm.

The farm is connected to the web [Disconnect](#) [Software Update](#)

Farm Name
Eran A_Irrigation

Farm Type
Irrigation

Baud Rate
9600
[Edit](#)
(Attention - Baud rate needs to be modified according to your communication device setup)
Restart is required for modifications to take effect

Com Port
COM1
[Edit](#)
(Attention - Com Port needs to be modified according to your communication device setup)
Restart is required for modifications to take effect

Your contact info for support

User Email Address
smith@email.com

[Save Changes](#) [Rescan Farm Houses](#)

Attached Web Groups
[Manage Groups](#)

Group Name	Owner
Test Irrigation	John Smith

Figure 35: Farm Settings Screen

- **Farm Name:** This is the name that appears on your screen.
- **Connect/Disconnect:** This function enables disconnect from the current farm from the internet and reconnecting it via the Log-in screen).

NOTE This function only appears on screens locally connected to the Comm-Box.

- **Farm Type:** Poultry, Pigs, or Irrigation. **Make sure that the definition matches the Comm-Box type!**
- **Baud rate:** This rate must be the same throughout the network.
- Com Port
- **Contact information (optional):** This information will be used by Netafim to contact users if there is a need; for example to inform you of an update. The information will not be distributed to any outside parties whatsoever.
- **Date and Time/Time Zone:** Edit as required.
- **Number of Houses to be Scanned:** Scanning tests communication to the houses. If you wish to scan all houses or individual houses, click the relevant house number. Click **Rescan Farm Houses** to complete the scan.
 - You can name the houses.
- Click **Save Changes**.
- System Update: Refer to Software Upgrade.

5.2.1.2 External Devices

Not applicable to irrigation systems.

5.2.1.3 Push Notifications

NOTE This tab and screen only appear when connected directly to the Comm-Box (meaning not via the web).

Comm-Box can send push notifications to multiple email addresses. These emails list:

- House/controller number
- Alarm time and date
- Alarm description

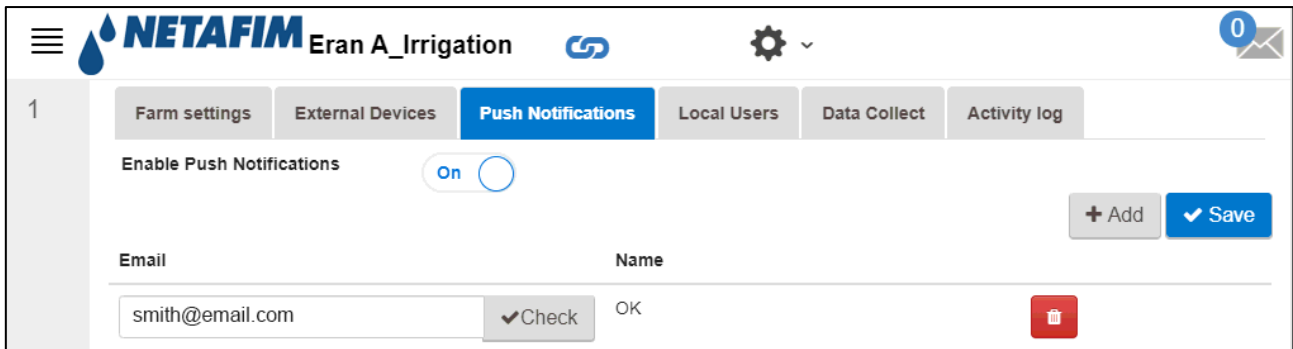

Figure 36: Push Notifications Screen

- Enter an address, click **Check**, **Add**, and then **Save**.

5.2.1.4 Local Users

NOTE This tab and screen only appear when connected directly to the Comm-Box (meaning not via the web).

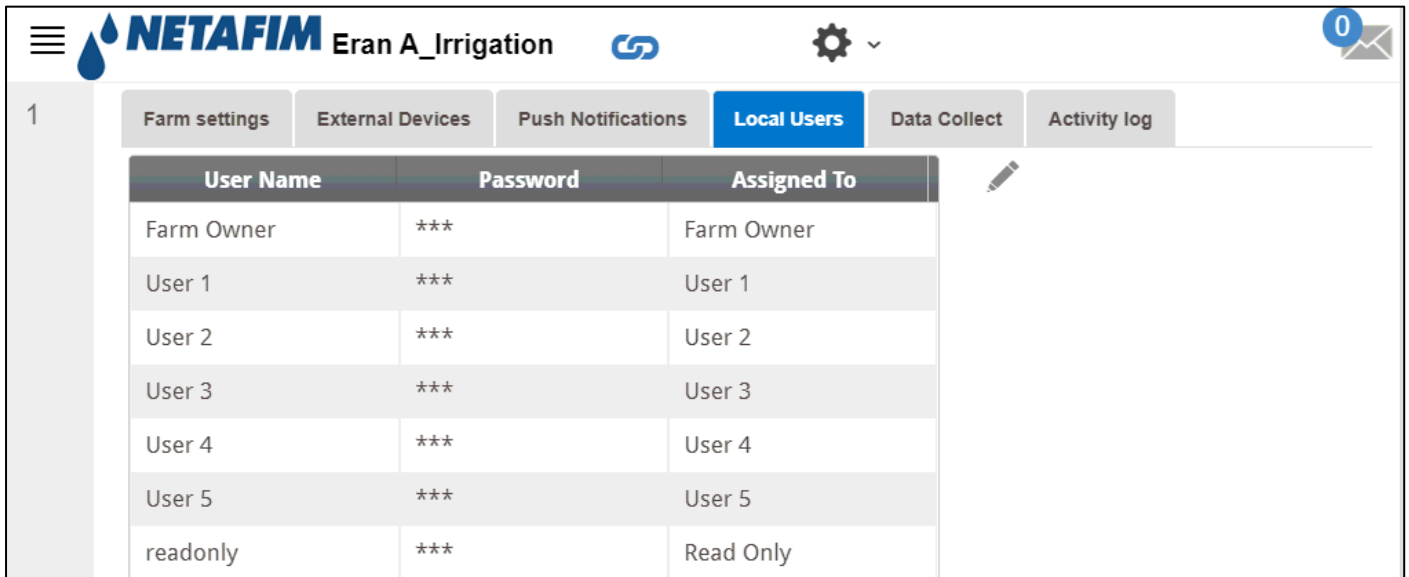

Figure 37: Password Definitions Screen

This screen lists pre-assigned user names and passwords.

- Each user name and password is the same. For example, User 1's password is User 1. User 2's password is User 2.
- The Farm Owner can edit these names, passwords, and to whom they are assigned.

5.2.1.5 Data Collect

Not applicable.

5.2.1.6 Activity Log

This screen displays the history of events connected to the Comm-Box. Under Event, Sub Event, User, and Cmd ID you can select filters to narrow down the results.

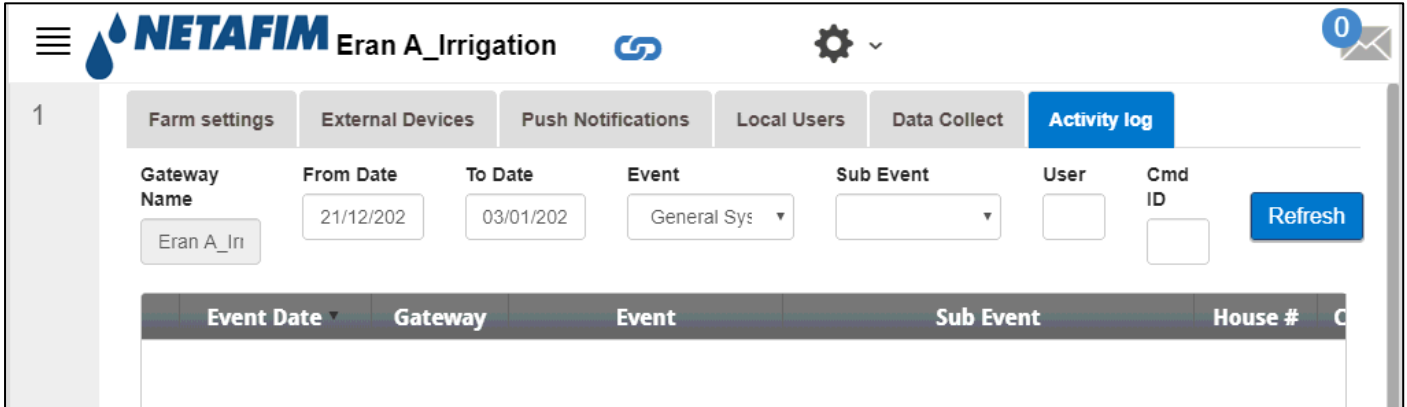

Figure 38: Comm-Box Events

5.2.2 House Scan Tab

The House Scan screen:

- Shows the results of the house scan.
- Show the controller type and software version used in each house.

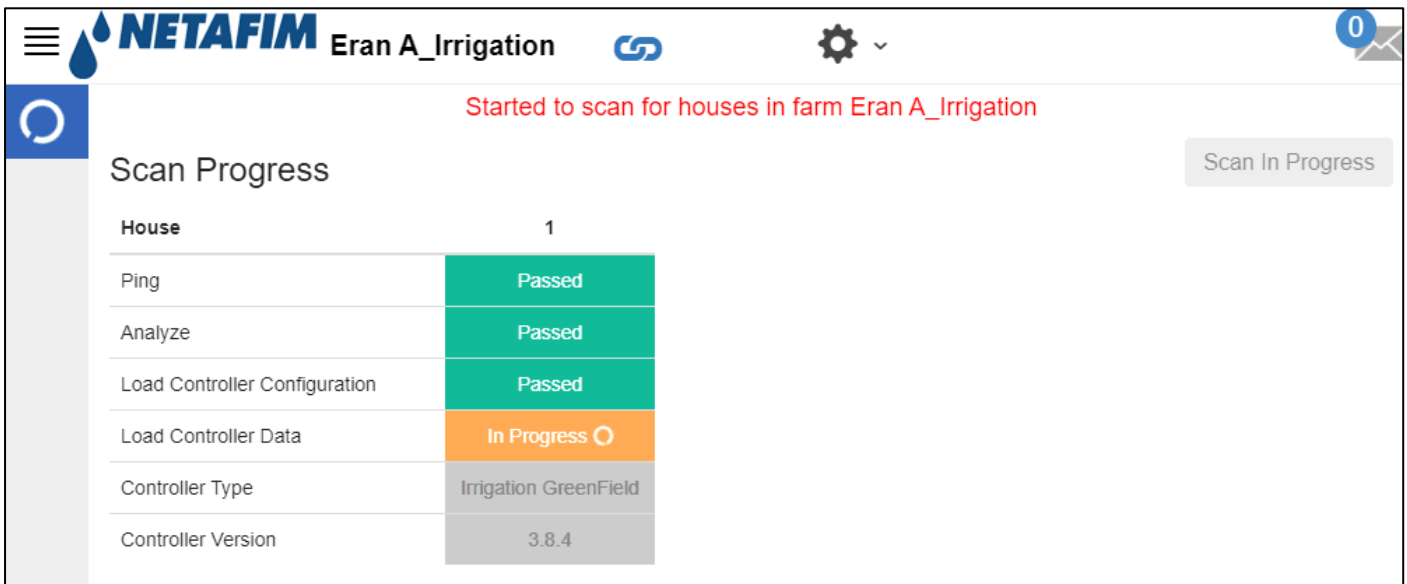

Figure 39: Scan Example

5.2.3 Diagnostics Tab

Comm-Box includes a basic diagnostics package.

- On the Activation screen click **Diagnostics**. The following screen appears.

NETAFIM Diagnostics Go Back

Comm-Box Details

Serial Number: 431605400000 ✓ Version: 1.50.7.99

Diagnostic Tests

Test Name	Test Instruction		Pass	Fail
Internet Connection	<ul style="list-style-type: none"> • Connect LAN cable To LAN Port 1 at The Comm-Box. • Press the Run Test Button. • Repeat Steps 1 to 2 for LAN Port 2. 	Run Test	✓	
Connection To Rotem WEB System	<ul style="list-style-type: none"> • Connect LAN cable To One Of The LAN Ports At The Comm-Box. • Press the Run Test Button. 	Run Test	✓	
Latest Image Version Installed	<ul style="list-style-type: none"> • This Test Verify That This Comm-Box Contains The Last Image Released. • This Test Done Automatically 	Run Test	✓	
Total Results:			3	

Speed Test

Figure 40: Diagnostics Screen

- This screen:
 - Supplies required data when speaking with technical support.
 - Enables a speed test.

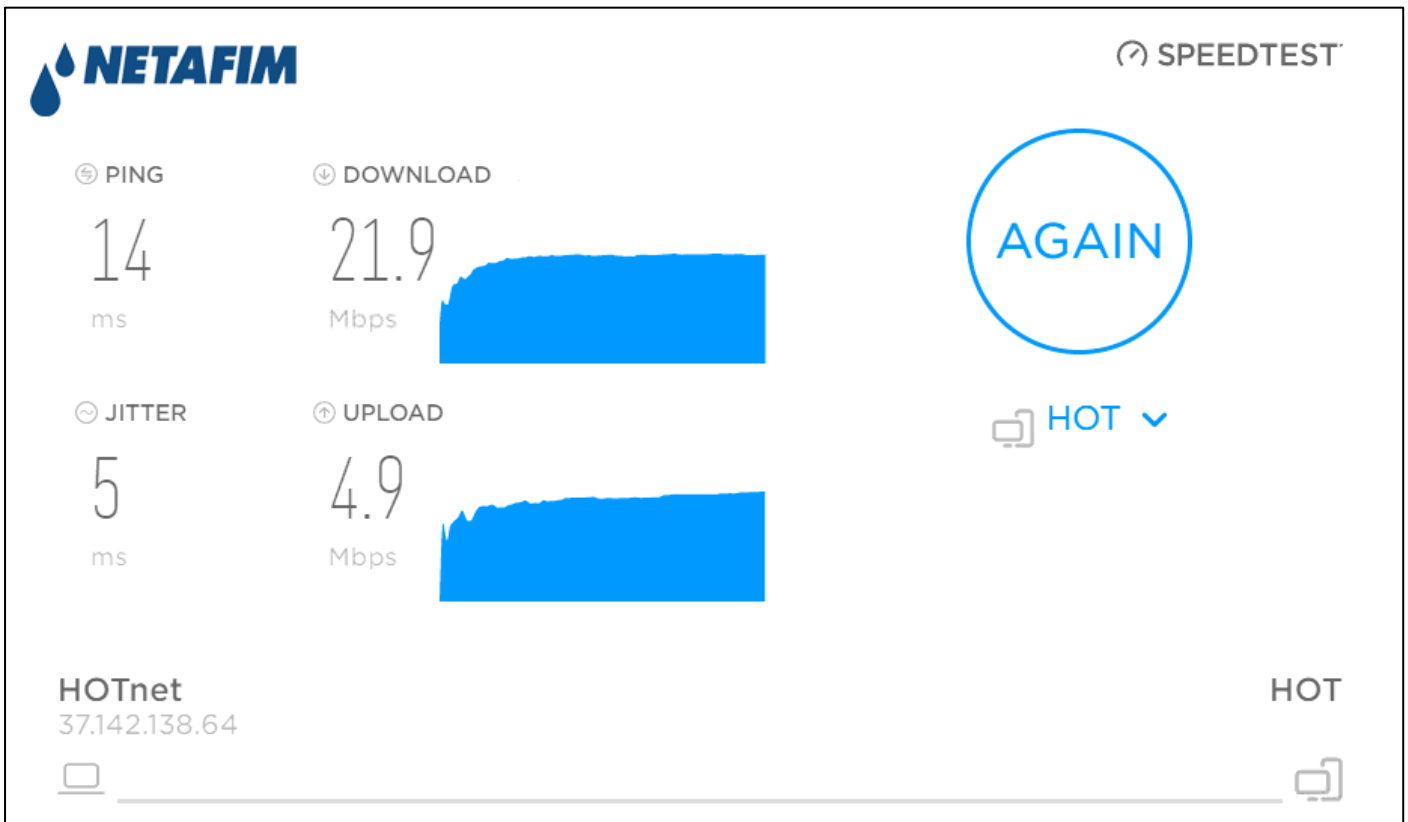

Figure 41: Speed Test

5.2.4 About Tab

This screen displays the product and software version. Send this information to technical support in the event that you require assistance. The Support ID enables remote technical support from Netafim or from your dealer.

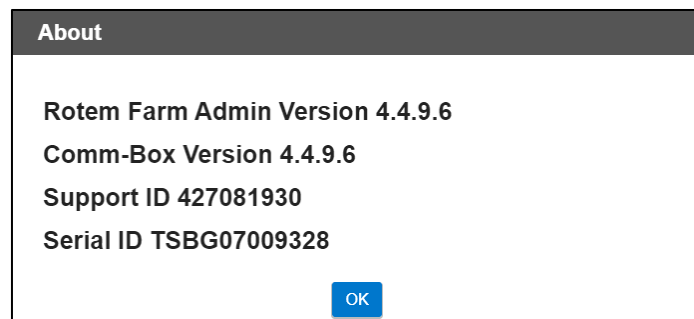

Figure 42: Tech Support Screen

5.3 Software Upgrade

You can upgrade certain software programs from the Web application.

- NMC AIR+ software
- Web application
- Comm-Box software

NOTE The Comm-Box can only be updated locally; it cannot be updated remotely. The System Update button does not appear in remote connections.

NOTE You cannot upgrade product software! Upgrade your product software using the procedures given in the product manuals.

NOTE If you are using a disk on key start here. If you are updating your Comm-Box via the web, go to step 4.

1. Request the software upgrade from your dealer. You will be sent (via email, web transfer, etc.) a UPD file.
 - a. Place the file on a disk on key/flash drive.
 - b. Place the disk on key/flash drive into the Comm-Box' USB port.
2. In the web application, click the **Farm Settings** tab. The following screen appears.

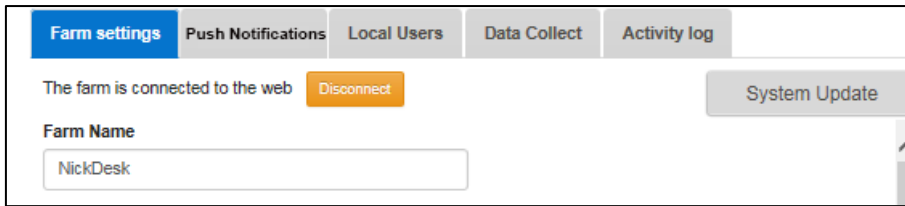

Figure 43: Farm Settings System Update

3. Click **System Update**. The following screen appears:

Version	Build	Release Date	Description	Type	Action
1.50.8	419	08/08/2020		Downgrade	Downgrade
1.50.8	4500	24/01/2022		Upgrade	Upgrade
1.50.8	437	18/01/2021		Downgrade	Downgrade
1.50.8	4496	09/11/2021		Reinstall	Reinstall

Figure 44: Update Software

- Users updating online: Click **Online Update** and choose the required software version.
- User updating using a flash drive: Click **Update from a removable drive** and choose the required software version.

NOTE If you did not place the disk on key in the USB port or if the disk does not contain a program, an error message appears.

The screenshot shows the NETA FIM update interface. At the top left is the NETA FIM logo. At the top right is a blue button with a left arrow and the text 'Go Back'. Below the logo is the section 'Update Commbox'. It contains a table with the following data:

Current Version	Build	Last Update	
1.50.8	4496	1/3/2022 06:25	Refresh Update List

Below the table is the section 'Available Updates'. It contains three buttons: 'Update from a removable drive' (highlighted in blue), 'Online Update', and 'Critical Online Updates'. Below these buttons is a large text message: 'Update Files Not Found'. At the bottom left of the interface, it says 'Version: 99.3.9.34'.

Figure 45: Error Message

6 WARRANTY

Controller:

Netafim warrants the electronic components of the Comm-Box on to be free of defects in materials or workmanship for **1 (one)** year from the date of purchase by end user. If a defect is discovered during the applicable warranty period, Netafim will repair or replace, at its option, the product or the defective part.

Note: lightning and surge damages are not covered by warranty.

Date of

Customer's representative:

Netafim's representative:

Name:

Name:

Signature

Signature
